



VibWire-301



Single Channel Vibrating Wire Sensor Interface

Last Updated Sept 6th 2024

Introduction

The VibWire-301 is a general purpose, DIN rail mounted single channel vibrating wire sensor interface that can be used in a wide range of applications. The VW-301 can be directly connected to any third party data logger or acquisition system supporting SDI-12, RS-485 and MODBUS digital communications, as well as analogue measurement capabilities. The device also supports 4-20 mA current loop operations.

The VibWire-301 uses the Keynes Controls auto-resonance Sensor Excitation technique, therefore no prior knowledge of the sensor operating characteristics is required. The device can be directly connected into many third party SCADA systems using the 4-20 mA current loop and Modbus operations..

Easy Use

The VibWire-301 is the latest in a range of Keynes Control vibrating wire sensor interfaces. The device has been designed from the outset for accuracy of measurement, ease of use, flexible use of communication systems.

The Auto-resonance sensor excitation ensures that no prior vibrating wire sensor operating characteristics need be known in advance, and the minimum wear for sensors.

Network Interfaces

The VibWire-301 supports SDI-12, RS-485, MODBUS Digital Communications. Analogue output (0-2 V DC), and 4-20 mA current loop operations within the same unit. The 4-20mA current loop, and 0-2 V DC output is supplied for both the frequency and temperature sensor signals.

DIN Rail Installation

The VibWire-301 is installed into enclosures using industry standard DIN rail. A clip on the bottom of the unit secures the device to the rail. A DIN rail mounted device enables fast installation, and replacement as necessary.

PC Based Data Acquisition

The VibWire-301 is fully integrated into the free Keynes Controls Q-LOG Data Acquisition and Display Software enabling the device to be used as a component part within a PC based Vibrating Wire sensor data acquisition system. The software can be used to configure, display and record measurements across a network.



VibWire-301 in a PC Data Acquisition System

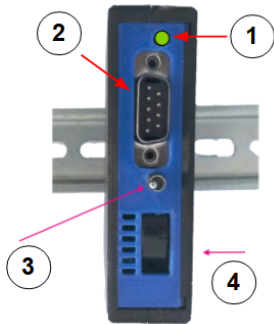

1. LED Status Indicator
2. RS232 Terminal Port
3. Speaker Switch
4. Speaker

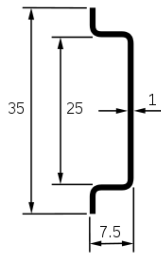

Top Hat rail IEC/EN 60715

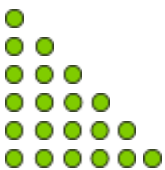

- 1 = 4-20 mA
- 2 = 0-2 V DC
- 3 = SDI-12
- 4 = RS485
- 5 = High Speed RS485
- 6 = MODBUS

The Status LED shows the User at a glance how the device has been configured.

Features

- 1 x 4 Wire Sensor Port
- Communications: SDI12 / RS485 / 4-20 mA / 0-2V DC / Modbus
- Auto-resonance Sensor Excitation
- 400Hz to 15 KHz Range
- Full User Configured Outputs - Hz , Digits, SI Units
- Fully Integrated into the Q-LOG Data Acquisition Software
- Supports 2 and 4 Wire Sensors
- Analogue Output 0 to 2 V DC Frequency and Temperature
- Current Loop 4 to 20 mA Outputs - Isolated to 500V DC
- DIN Rail Mounted Device
- MODBUS over RS485

High Speed Measurements

The VibWire-301 is capable of high speed sensor measurements. The basic model supports as standard 10 readings a second with the measurements stored directly into CSV file format.

Concurrent Measurements

The VibWire-301 is capable of simultaneous sampling operations for units on a network. The device supports the 'Concurrent' C! Command.

Q-LOG Windows PC Data Acquisition & Display Software

A complete version of Q-LOG without any restrictions can be download from http://keynes-controls.com/Download/QLogSetup50_21may2020.zip



VibWire-301

Single Channel Vibrating Wire Sensor Interface

Last Updated Sept 6th 2024



Technical Specification

Physical Size	Height 120 mm - Width 100 mm - Depth 22 mm
Weight	125 g
Power Supply	8-15 V DC
Communication Ports	1 x RS-485 Slave - 9600 Baud, 8 data, 1 stop, no parity 1200 Baud, 7 data, 1 stop, even parity 1 x SDI-12 - - 1200 Baud, 7 data, 1 stop, even parity
External Power Supply	8 - 15V DC @ 22 mA
Vibrating Wire Measurements	
Sensor Excitation	Auto-resonance - Fully automatic frequency selection
Operating Frequency	400 - 15 KHz
Measurement Resolution	0.01 Hz RMS - 20 to 70 Deg C
Measurement Accuracy	± 0.014% of reading - 20 to 70 Deg C
SI Units	Hz, Digits (Hz ² /1000), Eng Units (Quadratic Cal Factors)
Temperature Measurements	Thermistor Temperature Sensor
Analogue Input	24 Bit Sigma Delta
Analogue Output	0 - 2 V DC / 4-20 mA Temperature and Frequency
Current Loop Isolation	500V DC
Temperature Range	- 50 to 100 Deg C
Measurement Accuracy	± 0.25 % of reading - 20 to 70 Deg C
Output	Temperature - Deg C Frequency (Hz), Digits, SI Units
Temperature Sensor	Steinhart-Hart factors: A B C & D Beta Value - lower performance using Beta
Expansion Options 1 x MUX-16/32 expansion unit	1..32 - 2 X Wire Frequency or Temperature, 1..16 - 4 Wire vibrating wire sensor inputs
Scan Rate: Dynamic	10 - 20 Samples/ Sec (9600 B RS-485) - 10 Hz Analog Out 2 Sec/Chan - using expansion module 250 ms update
16 x 4 Wire / 32 x 2 Wire	30 Sec, 1 minute.

Optional USB Media Converters

An optional media converter can be used to connect the VibWire-301 to a Windows PC using either the SDI-12 or 485 digital networks.



Part No: **USB-485-Pro** Isolated RS-485 Media Converter
USB-SDI12-Pro Isolated SDI12 Media Converter

The vibrating wire sensor calibration factors can be assigned using the Q-LOG software in a Windows Environment.

Default Thermistor Settings

The factory set Steinhart-Hart Calibration Factors suitable for use with most vibrating wire sensors.

A	0.0033540	C	2.0829E-6
B	2.5627E-4	D	7.3003E-8

Analogue Output Ports / 0-2 V DC / 4-20 mA Loop

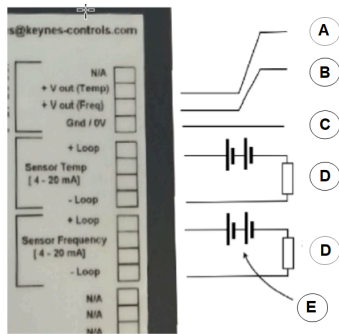

A = 0-2 V DC (Temperature)	B = 0-2 V DC Frequency
C = Gnd / 0V	D = Loop Sense Resistor
E = Loop Power Supply	

Connection to a Data Logger

The VibWire-301 connects to any third party data logger supporting SDI-12, 485 Communications or directly onto an analogue data acquisition.

Analogue Output Ports -- 0..2 V DC / 4..20 mA Loop

The analogue output ports, regardless of type, can be scaled to represent any measurement value in Hz, Digits and SI units for the frequency components, and Deg C for the temperature signal.

The device has isolated loops for both the frequency and temperature signals..The current loop opto-isolation prevents signal corruption due to ground loops.

Terminal Port Communications Setup

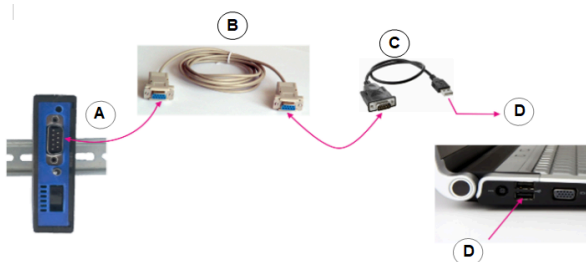

The VibWire-301 can be fully configured using the Terminal Port Menu system built into the device and accessed using the RS-232 Port mounted on the front of the device.

No device drivers are required when configuring the device using the RS232 port

A = RS232 Terminal Port Connection
C = RS232 to USB Converter
B = Null Modem cable
D = PCB USB Port

SDI-12 1200 = 1200 Baud, 7, E, 1 Stop
RS485 1200 = 1200 Baud, 7, E, 1 Stop
RS232 Terminal Port - 9600, 8, N,1,STOP



VibWire-301

Single Channel Vibrating Wire Sensor Interface

Last Updated Sept 6th 2024



Q-LOG Data Acquisition, Configuration and Display Software

Q-Log is the Keynes Controls Data Recording and Display software and has been designed solely for use with intelligent sensors and interfaces. The software operates as a stand-alone package and requires the use of an SDI-12, or RS-485 media converter. Q-LOG enables PC based systems to be created and tested. The software is free issued with the Keynes Controls instrumentation.

Common Keynes Controls device identifier strings.

Product	ID string
VibWire-201-Pro	13KEYNESVWRDOA001
VibWire-101 VW sensor interface	13KEYNESCOVW101A011
VibWire-108 VW sensor interface	13KEYNESCOVW108A016
PIEZO-RM water level sensor	13KEYNESCOPIRESR001
Barom-SDI-12 barometer	13KEYNESCOBAROMR003
I-P-1	13KEYNESCOIPINCL005
AquaDAT sensor interface	13KEYNESCOAQUADAT008
Single channel strain gage	13KEYNESCOSTRAIN027

Q-LOG Devices List Window.

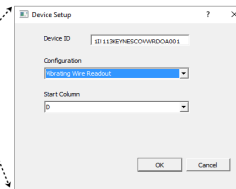
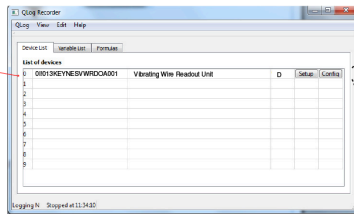

Fig-16

Image opposite demonstrates how the VibWire-301 is identified in Q-LOG. All the devices that are detected on a network are shown here.

Windows PC based Data Acquisition Systems

The simplest Windows PC based vibrating wire sensor solution is shown below. A Windows PC running Q-LOG and an isolated USB media converter..



1. Windows PC running Q-LOG
2. USB Data Link
3. Optional Media Converter

Part Number: USB-SDI12-Pro (SDI12 Network)
USB-485-Pro (RS485 Network)

The Keynes Controls media converters can power the VibWire-301 directly from a laptop / Desktop USB Port without the use of an external power supply.

Configuration

The measurements are recorded into unique time stamped text files that can be read by a spreadsheet. Information is easy to understand and process.

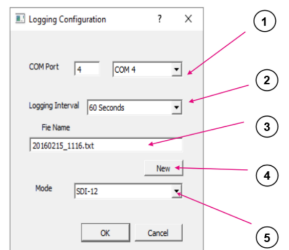

Q-LOG Network Configuration Window

YOUTUBE

Youtube: <https://youtu.be/px0O7UZbX5g>

Q-LOG Data Display

The Q-LOG software can be used to:

1. Display Results in - Hz / Digits / Engineering Units
2. Real-time Charts.
3. User Defined Panel meters

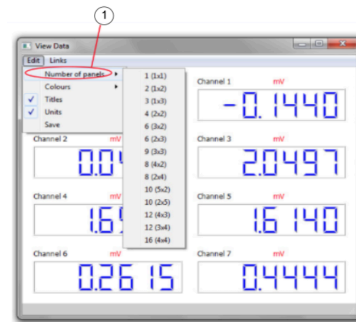

Q-LOG Panel Meter Selection Window

No programming experience is required. The sensor calibration factors can be written directly into the device. Their panel meters can be used to display sensor results.

Youtube Video Title: **VW-301 Qlog Basic Operations**

See: <https://youtu.be/gWV1D8KPPfc>

Data Acquisition and Testing

The Q-LOG software is an ideal tool for testing measurement systems in the workshop before installation on site, Sensors can be configured, test measurements made, results displayed for easy analysis.

Confidence can be made in the measurements before any installation onto data recorders or site wide monitoring systems.

Configuration Settings

1. Enter Comm Port identified for USB media converter
2. Data Recording Sample Rates
- (1, 5, 10 Secs, 1 to 10 minutes, 1 and 6 Hours)
3. Time stamp Log Filename
4. New Button
- Automatically create a new time stamped log file.
5. Network Type Selection - SDI-12 / RS-485.



VibWire-301



Single Channel Vibrating Wire Sensor Interface

Last Updated Sept 6th 2024

SDI-12 / RS-485 Supported Commands

The following commands are supported by the VibWire-301 and are used by data loggers and data acquisition systems. The commands have been included to allow the VibWire-301 to operate easily with third party data loggers that support industry standard SDI-12 command set.

Start Measurement: M0! D0! – is the main command required to start a measurement and return the data to a logger unit or PC data acquisition system.

Description	Master	VibWire-301 Response
Acknowledge active	a!	a!\r\n
Send ID: provided to complement SDI-12 protocol	a!	a13KEYNESVWRDOA001\r\n Part Description assigned by Keynes
Address Query identifies instrument address and commonly used on single instrument operations only.	?!	a!\r\n
Change Address: used to change instrument address from a (initial) to b new ID for network operations	aAb!	Where a = ID number 0 - 9 (standard) / (a..z) Enhanced SDI-12 0 - 9 / a - z for RS485
Start Measurement instruct an instrument to make measurement	a = initial address b = new address aM!	b!\r\n a : b = number 0 - 9 or a - z a0261\r\n
Concurrent measurement: Used for starting a measurement for all instruments on a network at the same time.	a = address of instrument example 0M! starts scan for ID 0 aC!	instrument with address a returns 1 x 4 wire reading in 1 second. a0268\r\n
This command frees RS-485 bus for other devices	start measurement instrument address 'a'	initial response only after receipt of instruction and no response when data ready to be sent.
MUX-16/342 Expansion Unit	32 x 2 Wire Measurements aM2! aD0! aD1! aD2! aD3! - 16 x Freq aM3! aD0! aD1! aD2! aD3! - 16 x Freq	+xxxx.x+xxxx.x+xxxx.x+xxxx.x\r\n
Thermistor 1 & 2	16 x 4 Wire Measurements aM2! aD0! aD1! aD2! aD3! aD4! aD5! aD6! aD7! D0-D4 = Frequency D4-D7 = Temperature VibWire-301 supports 2 thermistor types	
Thermistor Type 1 Temperature sensor settings Parameters from the sensor calibration sheet Steinhart-Hart Parameters Thermistor resistance/temp calculation	aXT1RE! aXT1T0! = 25 aXT1BET!	Resistance at 25 Deg C T0 - generally 25 Deg C Beta Value
Thermistor Type 2 Temperature sensor settings Parameters from the sensor calibration sheet Steinhart-Hart Parameters Thermistor resistance/temp calculation	aXT2ST0! aXT2ST1! aXT2ST2! aXT2ST3!	A in Steinhart-Hart B in Steinhart-Hart C in Steinhart-Hart D in Steinhart-Hart
VW Sensor Input Channel Settings Sets the process option for frequency calculations	aXT2RE! aXT2T0! = 25 aXT2BET!	Resistance at 25 Deg C T0 - generally 25 Deg C Beta Value
Thermistor Temperature Calculation	aXT2ST0! aXT2ST1! aXT2ST2! aXT2ST3!	A in Steinhart-Hart B in Steinhart-Hart C in Steinhart-Hart D in Steinhart-Hart
	aXCH0FN!	0 = output in Hz 1 = output in digits = F ² /1000 2 = use formula A + B*digits + C*digits ² + D*temperature digits = Frequency ² in units of Hz ²
	F = Frequency type N = VW Channel 0 .. 7	0 = resistance ratio - thermistor data sheet (R _r /R ₂₅) 1 = Beta value calculation 1/T = 1/T ₀ + log(r)/Beta where r = R _r /R ₂₅ 2 = Steinhart-Hart equation 1/T = A + B(Ln R _r /R ₂₅) + C(Ln R _r /R ₂₅) ² + D(Ln R _r /R ₂₅) ³
	aXT1TYn! a = ID n = integer 0	

Sensor Connection

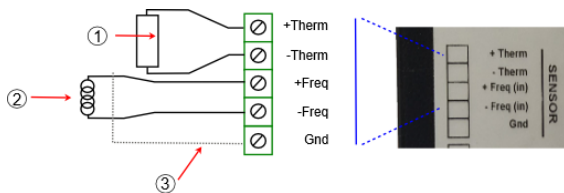

1. Thermistor Temperature Sensor.
2. Vibrating Wire Sensor.- 2 or 4 Wire.
3. Earth / Shield.

Calculations

The VibWire-301 can be configured to convert frequency into engineering units. The common calculation for vibrating wire sensors uses Digits. Keynes Controls defines the Digits calculation as:

$$\text{Digits} = \frac{\text{Frequency}^2}{1000} \frac{(\text{Hz}^2)}{1000}$$

$$\text{SI Units Calculation} \quad X = A + Bd + Cd^2 - D(T)$$

where **d** = measured frequency in Digits.
and **D** = Temperature Correction Coefficient
T = Temperature in Deg C



VibWire-301

Single Channel Vibrating Wire Sensor Interface

Last Updated Sept 6th 2024



High Speed Measurements - 4-20 mA / 0 - 2 V DC

The VibWire-301 can operate in high speed mode. The simplest way to use the device in high speed mode is to connect it to an analogue data acquisition system via the 0-2 V DC or 4-20 mA loop output ports. The analogue output ports can also be used to drive process display units.

The device has two analogue output signals that can be individually configured to represent the sensor frequency in Hz, Digits or SI Units. The temperature sensor output can be scaled to represent Degree Celsius or mV. High speed vibrating wire measurements

Analogue Output Port Connection

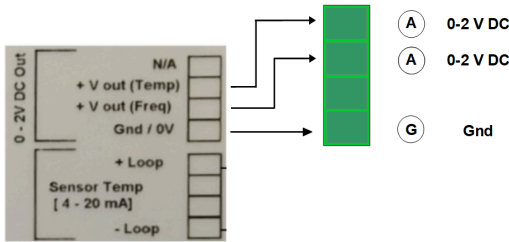

A = Analogue Input 0-2 V DC (Frequency and Temperature signals)
G = Gnd/ 0V

The menu system below are the default settings for a vibrating wire sensor operating over the range 500 - 1300 Hz as used by the Geokon 4200 sensor.

Sensor Setup

1 Frequency proc	Hz
2 Center Frequency (Hz)	900
3 First Ping (us)	5000
4 Cal A	0.
5 Cal B	1.0000
6 Cal C	0.
7 Cal D	0.
8 Stabilization after pluck (us)	5000
9 Sample number of pulses	20

The configuration settings show the output signal from the device will represent a Vibrating Wire signal in Hz.

Current Loop Port 4-20 mA

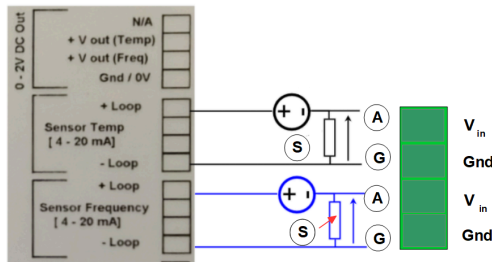

The VibWire-301 supports two individually isolated 4-20 mA loop outputs that can be configured to represent the Frequency and temperature signal components of the sensor. The current loop not only represents the sensor signal but is also powered from it.

A precision 100 Ohm sense resistor is used to convert the loop signal to a voltage that can be measured by an analogue data acquisition system.

The sensor output signal can be configured to represent Hz, Digits or SI units.

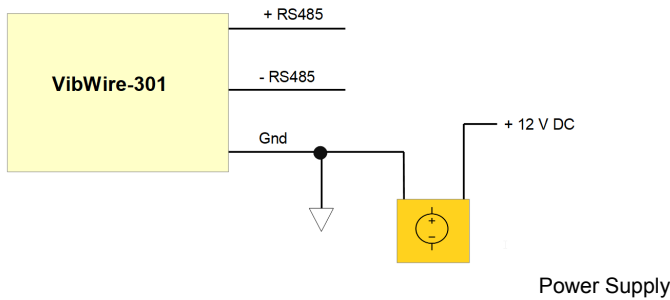

Power Supply / Earth Connection

Connect the VibWire-301 to a power supply as shown in the figure opposite.

The 0V / Gnd connection of the DC power supply connects to the Gnd connection on the VibWire-301

Incorrect power supply connection can stop the VibWire-301 from operating correctly.

Terminal Port Connection

The VibWire-301 can be configured using the terminal port menu system and can communicate with any intelligent supporting RS-232 communications. The terminal port does not require any driver or application software. Any device that supports terminal connection can be used.



NULL Modem Cable - Pin-outs

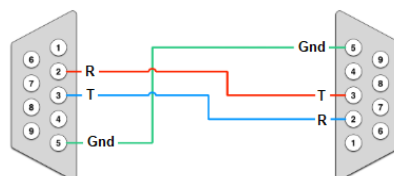

A 9-Pin Null-Modem cable connects the 9-PIN D connector port on a USB to RS232 converter to the terminal port on the instrument.

where R = Receive
T = Transmit
Gnd = Ground.



VibWire-301



Single Channel Vibrating Wire Sensor Interface

Last Updated Sept 6th 2024

MODBUS Registers

16 / 32 Bit - MODBUS Data Format

The MODBUS version of the instrument stores data into a series of 4 byte registers as shown below. Measurements are processed as a floating point 4 byte number. The data is in HEX format with the high word being the first 2 bytes and the last being in the next 2 bytes as shown.

The VibWire-301 supports both 16 and 32 bit format MODBUS registers.

MODBUS ID Number : Integer 1 .. 255

The MODBUS ID number is used to identify the instrument on a MODBUS network. This must be assigned for the instrument to communicate on a MODBUS network.

System Information

The last 2 registers in the VibWire-103 are used to check the data integrity. Register with address 32 increments upon the completion of an instrument scan and is used to show that the instrument is still operating.

Register with address 6/7 increments when the VibWire-301 receives a new MODBUS 'Read Input Registers' FC=04 command.

	2 Bytes	2 Bytes
Floating Point Data Value	High Word	Low Word

32 Bit Floating Point Registers

The table below shows how the registers holding the VibWire-301 32 bit (floating point) data is stored.

32 Bit Floating Point Registers

Address Offset	Parameter	Description
0	Frequency Signal	High Order Word
1		Low Order Word
2	Processed Value	High Order Word
3		Low Order Word
4	Temperature	High Order Word
5		Low Order Word
6	Number MODBUS read operations	High Order Word
7		Low Order Word

32 Bit Signed Integer Registers

Address Offset	Parameter	Description
256	Frequency Signal	High Order Word
257		Low Order Word
258	Processed Value	High Order Word
259		Low Order Word
260	Temperature	High Order Word
261		Low Order Word
262	Number MODBUS read operations	High Order Word
263		Low Order Word

16 Bit Integer Registers

Address Offset	Parameter	Description
128	Frequency Signal	Integer
129	Processed Value	Integer
130	Temperature	Integer
131	Number MODBUS read operations	Integer

32 Bit Signed Integer x 10 Registers - High Resolution

Address Offset	Parameter	Description
384	Frequency Signal	High Order Word
385		Low Order Word
386	Processed Value	High Order Word
387		Low Order Word
388	Temperature	High Order Word
389		Low Order Word
390	Number MODBUS read operations	High Order Word
391		Low Order Word



VibWire-301



Single Channel Vibrating Wire Sensor Interface

Last Updated Sept 6th 2024

MODBUS over 485 Network

The images below show the Configuration Settings for the MODBUS POLL software that Keynes Controls uses to test the MODBUS version instruments.

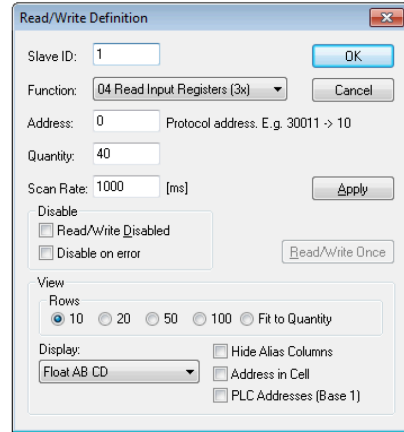
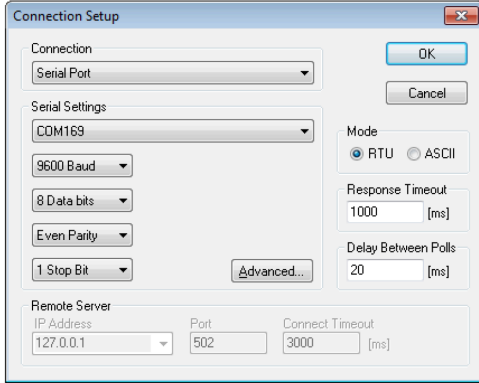

MODBUS Operations

The VibWire-301 will connect to any suitable MODBUS Master supporting RS-485 digital communications. This could be a plant wide SCADA solution or simply a stand-alone system running on a PC or laptop. So long as a suitable communications port is available then the instrument will communicate.

The Keynes Controls model USB-485 media converter can be used with MODBUS communications. Any other similar device can be used with the instruments.

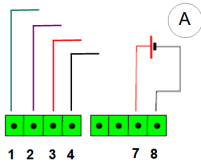

1 = + RS486 2 = -RS485 3 = +12V DC 4 = Gnd / 0V

Technical Specifications

Description	
1 x USB Type B	User assigned cable length
1 x Network Port	SDI12 or RS485 Port
1 x External Power Port	9.5 to 16 V DC - 1 Amp (Excludes USB-SDI12-Post model)
1 x Power Indicator LED	USB Supply Level exceeds 9.5 V DC / Short circuit detection
1 x Port Status Indicator	Used to show PC Port operating to specification and can power instruments
Direct Connection Power	Maximum current 150 mA without external source
External Power	1 x External supply 9.5 - 16 V DC
Short Circuit Protection	Automatic reset - network + 12 V DC to Gnd
Opto-isolation	1000 V DC SDI-12 Data to Gnd
Connector	2 x 4 way - 3.5 mm pitch screw lock.
Chip Set	FTDI - uses Windows 10 Microsoft Accredited Driver

Parity = Even

The VibWire-108-Modbus operates as a /slave system where the SCADA system or data recorder is the master.

Q-LOG MODBUS Settings

The Q-LOG software can be used to assign the MODBUS communications parameters and to switch the instrument into MODBUS Mode of operation. See image "VibWire-301 QLOG Applications Software Configuration Window" Page 8.

Communications Mode = 6
MODBUS Address = Integer 1-255

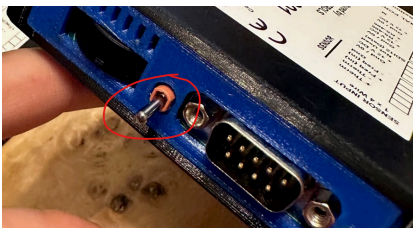

Sensor Speaker

The VibWire-301 has a built-in ceramic speaker for the user to listen to the sensor return signal. The switch mounted on the front of the instrument is used to activate the speaker unit.



VibWire-301

Single Channel Vibrating Wire Sensor Interface

Last Updated Sept 6th 2024



VibWire-301 Port Pin-Outs

The image below shows the pin-outs for the Sensor and Communications Ports available on the VibWire-301 Vibrating Wire Sensor Interface.

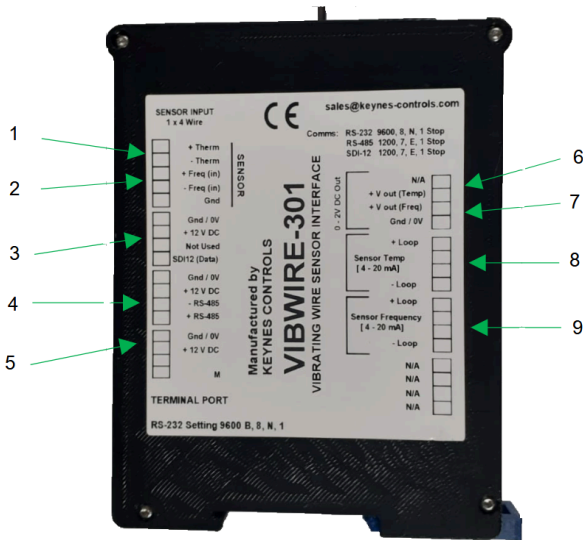

Property	Value	tool	Set
Identify	14KEYNESCOVW301A022		
Identify	14KEYNESCOVW301A022		
Communication mode	1	Tool	Set
RS485 baud rate	1200	Tool	Set
Modbus Address	1	Tool	Set
Frequency output	DIGITS	Tool	Set
Centre frequency	2000	Tool	Set
First Ping	5000	Tool	Set
Cal A	0.00000	Tool	Set
Cal B	1.0000	Tool	Set
Cal C	0.00000	Tool	Set
Cal D	0.00000	Tool	Set
Stabilization after pluck (us)	5000	Tool	Set
Sample number of pulses	50	Tool	Set
Therm 1 Type	2	Tool	Set
Therm 1 resistance at T0 (ohms)	3000.0	Tool	Set
Therm 1 T0 (Celsius)	25.000	Tool	Set
Therm 1 Beta	0.00000	Tool	Set
Therm 1 Steinhart-Hart 0th order (A)	0.0033540	Tool	Set
Therm 1 Steinhart-Hart 1st order (B)	2.5627E-4	Tool	Set
Therm 1 Steinhart-Hart 2nd order (0)	2.0829E-6	Tool	Set
Therm 1 Steinhart-Hart 3rd order (C)	7.3003E-8	Tool	Set
Frequency 4-20mA : Value at 4mA	1440.0	Tool	Set
Frequency 4-20mA : Value at 20mA	16000	Tool	Set
Frequency 4-20mA : DAC for 4mA	10922	Tool	Set
Frequency 4-20mA : DAC for 20mA	54613	Tool	Set
Temperature 4-20mA : Value at 4mA	-40.000	Tool	Set
Temperature 4-20mA : Value at 20mA	120.00	Tool	Set
Temperature 4-20mA : DAC for 4mA	10922	Tool	Set
Temperature 4-20mA : DAC for 20mA	54613	Tool	Set
Frequency 0-2V : Value at 0V	0.00000	Tool	Set
Frequency 0-2V : Value at 2V	16000	Tool	Set
Frequency 0-2V : DAC for 0V	0	Tool	Set

VibWire-301 QLOG Applications Software Configuration Window

The QLOG Applications software which is supplied freely with this product can be used to configure the instrument, make test measurements and display results.

Ports

- 1 Vibrating Wire Sensor - Temperature Sensor
- 2 Vibrating Wire Sensor - Frequency Sensor Component
- 3 SDI12 Port
- 4 RS-485 Port
- 5 Power Connection Port
- 6 0 - 2 V DC - Temperature Signal Component Output
- 7 0 - 2 V DC - Frequency Signal Component Output
- 8 4-20 mA - Temperature Signal Component Loop Output
- 9 4-20 mA - Frequency Signal Component Loop Output

Communication Port Settings

- RS-232 Terminal Port** 9600, 8, N, 1, STOP
- RS-485 Network Port** 1200, 7, E, 1, STOP
- SDI12 Network Port** 1200, 7, E, 1, STOP

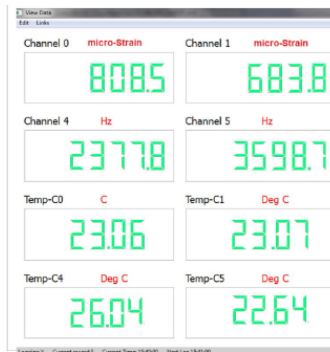

Panel Meter Display - QLOG Vibrating Wire Sensor Results